

## Overview

The FM Rev3.15 is a professional quality phase-locked-loop (PLL) based FM transmitter designed to operate in the frequency range 87.5 to 108 MHz. The FM 3.15 has the following features, it:

- Uses a half-frequency oscillator, to get round the feedback problems that an at-frequency oscillator can suffer from in RF hot environments
- Will produce a solid 1 Watt across the band
- Has an output that is legally clean enough to either be connected directly to an antenna, or amplified to high power (nothing over 60dB below the carrier)
- Doesn't use any micro-controllers and thus does not require any software to be written/blown
- Has out-of-lock power-down to stop transmissions on unwanted frequencies whilst the phase lock loop is settling down
- Is straightforward to set onto the desired frequency
- Has a flat frequency response from around 3 Hz to at least 100 kHz, providing superlative modulation
- Does not need any tuning (other than setting the VCO frequency)
- Can have its output quickly disabled (i.e. for connection to a high SWR detector)

The FM 3.15 uses a half-frequency oscillator, meaning that even when amplified to high powers, the impact of any radio frequency (RF) feedback is minimised, improving stability and reducing buzz when the transmitter is located close to the antenna.

## Setting the frequency

The positions of the DIP switches required to set the transmitter to a particular frequency can be found at:

- [www.zynq.uk/tx/](http://www.zynq.uk/tx/)

When you have set the switches to the correct positions for the frequency you wish to use, ensure that the RF output is connected to a 50 Ohm load and apply a 12V power source. Gently rotate the variable capacitor until the 'LOCK' LED lights. Once it has lit, measure the voltage at TP1 and again slowly rotate the variable capacitor until this is in the range of 5V to 9V. This will ensure optimum modulation performance and completely reliable lock.

It is possible to carefully compress or expand the turns of inductor L5 (8 turns – situated next to transistor Q2) to maximise the brightness of the 'PSWR' LED. This will maximise the output power of the transmitter.

No other adjustments are necessary. The output power of the transmitter should reach 1 Watt for a 13.8 Volt supply. Do not exceed 15 Volts on the power supply.

The modulation input to the transmitter is very sensitive, only a few hundred millivolts of audio are required for full deviation. Note that the input is not pre-emphasised and is intended for a pre-emphasised input (or a stereo MPX input). If pre-emphasis is required, please use the following circuit at the audio input to the transmitter (components not supplied).

**Note:** Some people have found that replacing C39 with an 18 pF capacitor (originally 15 pF) improves the transmitter power output towards the bottom of the band (i.e. below 90 MHz).

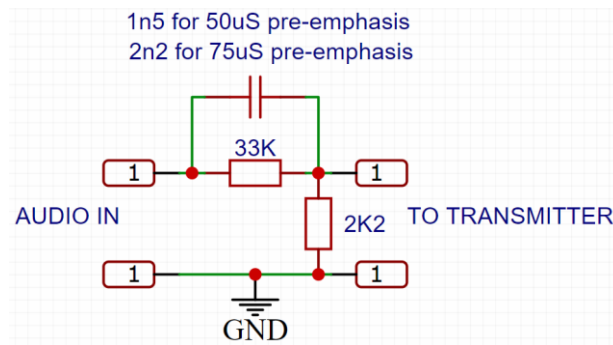

## PCB Layout

The layout of the PCB is replicated below for reference.

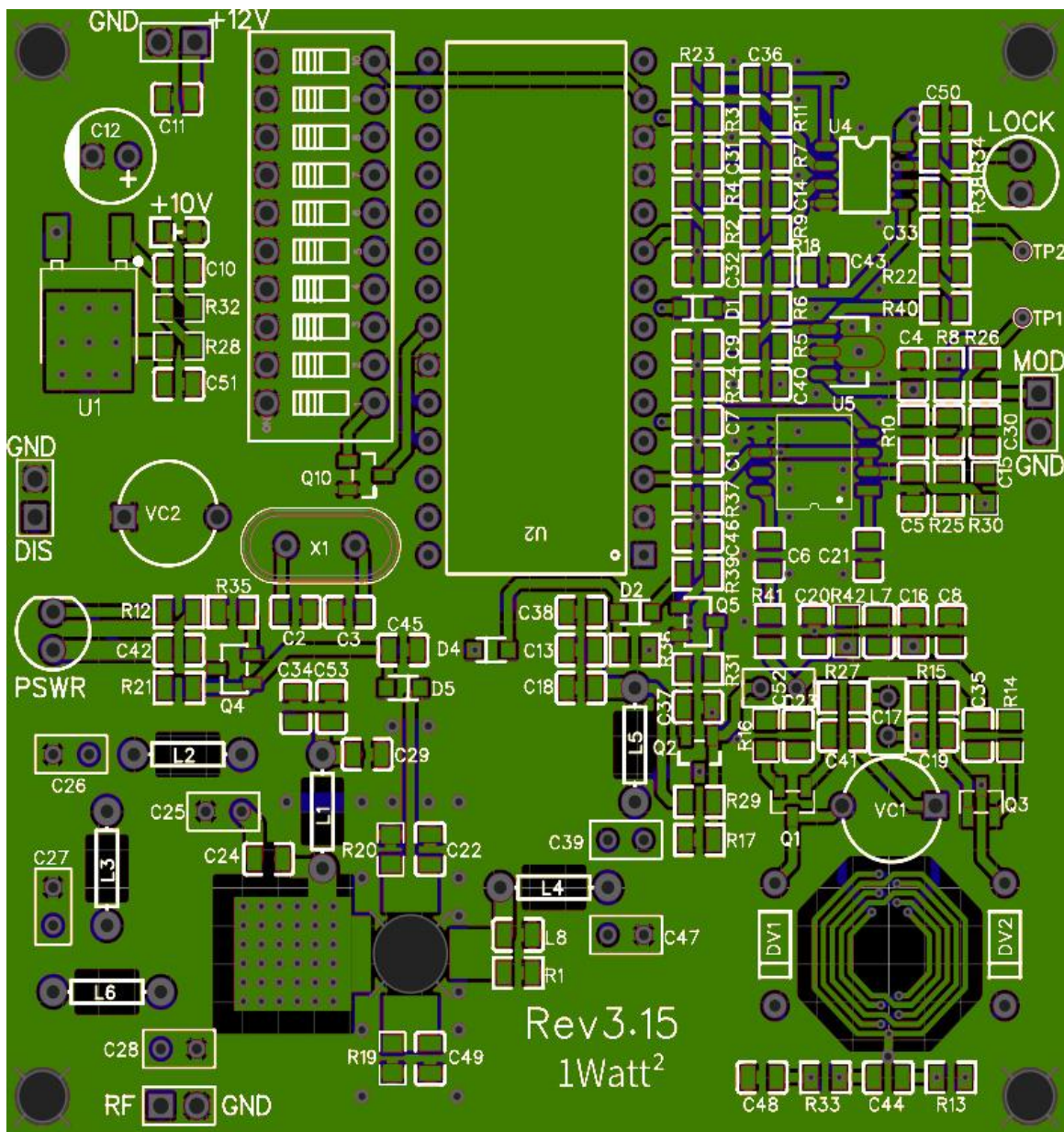

## Connections and Indications

The various connectors are as follows:

- +12V Input for power source
- RF Output of the transmitter
- MOD Modulation (audio) input
- DIS Ground this to rapidly disable the output (i.e. for connection to a high SWR or heat detector on an associated amplifier)

The LED's have the following functions:

- LOCK This indicates that the PLL is locked onto the wanted frequency
- PSWR This measures the current flowing through the output transistor