

Overview

The FM Rev3.07K is a professional quality phase-locked-loop (PLL) based FM transmitter designed to operate in the frequency range 87.5 to 108 MHz. The FM 3.07K has the following features, it:

- Uses a half-frequency oscillator, to get round the feedback problems that an at-frequency oscillator can suffer from in 'RF hot' environments
- Is built from the minimum sub-set of components, to keep the cost of getting all the parts together as low as possible
- Doesn't use lots of expensive or difficult-to-get-hold-of parts
- Can accommodate different output transistors (such as the 2N4427, MRF237 and similar)
- Can use a range of transistors for most of the parts (such as the BF199, MPSH10 and similar)
- Will produce around 1 Watt across the band with as little fiddling as possible (or more depending on the output transistor)
- Has an output that is legally clean enough to either be connected directly to an antenna, or amplified to high power (nothing over 60dB below the carrier)
- Keeps the digital and analogue parts of the circuit as separate as possible to minimise digital noise on the modulation
- Doesn't require any micro-controllers and thus does not require any software to be written/blown
- Has out-of-lock power-down to stop transmissions on unwanted frequencies whilst the phase lock loop is settling down
- Is straightforward to set onto the desired frequency
- Can be easily tested and maintained (to the extent that it could be built in stages, testing each along the way)
- Has a flat audio frequency response from around 3 Hz to at least 100 kHz, providing superlative modulation
- Does not need any tuning (other than setting the VCO frequency)
- Can have its output quickly disabled (i.e. for connection to a high SWR detector)

The FM 3.07K uses a half-frequency oscillator, meaning that even when amplified to high powers, the impact of any radio frequency (RF) feedback is minimised, improving stability and reducing buzz when the transmitter is located close to the antenna.

Using the standard output transistor, the design will produce around well over 500 milliWatts with a 12 Volt supply rising to 1 Watt with a maximum 15 Volt supply across the whole frequency range. Other output transistors can be used, with output powers of over 2 Watts possible.

Compared to many other similar transmitters, the FM 3.07K uses a very low PLL loop frequency. This means that the PLL does not attempt to 'correct' bass modulation and together with the careful design of the circuit, means that the frequency response is flat to from around 3 Hz to over 100 kHz, ensuring very clean and accurate modulation.

An out-of-lock power down circuit ensures that there is no output from the transmitter until the PLL is locked, preventing emissions on frequencies other than that to which it is set (which can be disastrous for high power amplifiers when connected to a narrow-band antenna).

The output of the transmitter is filtered by a 7 pole low pass filter, reducing all spurious outputs to at least 60 dB below the main carrier. This exceeds the harmonic output requirements of Ofcom's Site Engineering Code for Analogue Radio Systems.

Please read the instructions in full before beginning construction.

Important Notice: A licence is normally required to connect this transmitter to an antenna. Please ensure that you have the necessary authorisations before using this device with an antenna.

Construction

To construct the kit you will need:

- A soldering iron, preferably with a narrow tip
- Solder
- A pair of snips or side cutters to trim component leads once devices are soldered to the board
- A 4mm former for winding coils (the smooth end of a 4mm drill bit is ideal for this)

Check that you have all the parts by comparing those supplied with the parts list and familiarise yourself with which components are which.

In general, when loading components into a PCB, the principle used is to start with those with the shortest profile (i.e. diodes and resistors) and end with those with the tallest profile (i.e. electrolytic capacitors). All components should be mounted as flush to the PCB as possible.

Start by fitting all of the diodes, including the varicap diodes which sit next to octagonal PCB inductor.

Next fit all of the resistors, the ferrite bead (L9), and the two 1 uH inductors (which look like slightly thicker resistors). Help with identifying resistor colour codes can be found online at:

- www.wirelesswaffle.com/resistors/

Continue by fitting the TO-92 style transistors (do not, at this point, fit the output device). Note the orientation of the transistors as marked on the board. In all cases, it should be possible to mount these transistors flush to the circuit board. The 6.4 MHz crystal can also be fitted.

The small ceramic capacitors should be installed next (not the tall electrolytics). These should be fitted as close to the board as possible, ideally with any excess leads above the board no longer than 1mm long.

Next install the 4 IC's. Be careful when fitting the CMOS IC's as they can be sensitive to static. A good precaution is to solder the 'ground' pin first (pin 8).

Continue by installing the 10 way switch, the 100nF capacitors and the LED's, carefully noting the orientation of the LED's (there is a flat on the LED and on the board). Next install the electrolytic (tall) capacitors, the negative lead (marked on the side of the capacitors with a stripe) should be in-line with the solid bar marked on the PCB. Finally connect the LM317, the side with the metal tab facing the outside of the PCB. This should push down to be flush with the PCB.

At this point, some tests of the board can be conducted. Set the DIP switches to a frequency of 108 MHz (off-off-off-on-on-on-off-off-off-on as seen from left to right). Note that ‘left hand’ and ‘right hand’ refer to the board as viewed from the top with the IC’s at the top of the board.

Connect a 12 to 15 Volt supply to the board (the positive goes to the square hole labelled ‘+12V’ and the negative to the round hole next to it). With the power connected, the following can be checked

- The ‘+10V’ and ‘+5V’ LED’s should light up.
- If you have a receiver capable of receiving a frequency of 6.4 MHz (short wave), you should be able to hear a silent carrier on this frequency.
- Check that the following voltages are as indicated (anything within half a Volt of these values should be more than adequate)

Measurement Point	Approximate Expected Voltage
4046, pin 16	9.5 V
74HC4060 and 74HC4040, pin 16	5.5V
74HC4060 (left hand IC), pin 13	2.6V (actually a ~400 Hz square wave)
74HC4040 (right hand IC, near to the LM317), pin 10	2.6V

If the above voltages are correct, it is likely that the PLL will lock on a frequency of 108 MHz and the ‘LCK’ LED will light.

Now wind the five coils with the following number of turns:

- L1 has 6 turns
- L2, L3 and L8 have 5 turns
- L5 has 8 turns
- L7 has 2.5 turns

All of the coils should be wound tightly on a 4mm former (such as the shaft of a 4mm drill bit, or a piece of 4mm wooden dowel) using 0.56 mm diameter wire. Leave enough additional wire at the end of each coil to form legs that can be used to mount the coils on the board. Remember to strip the insulation off each end of the enamelled wire so that it can be soldered. The finished coils should look something like the picture below (the example shown has 6 turns).



Once all the coils are wound and installed, re-connect the power and check the following voltage:

Measurement Point	Approximate Expected Voltage
Left hand side of the 47 Ohm resistor next to L5	1V

It is now time to fit the output transistor (2N4427 or whatever is your preference). The output transistor should be mounted so that it is flush with the top of the PCB, with the metal lug on the transistor in the same position as the lug indicated on the PCB (note that the position may need to be reversed for some alternative transistors). This transistor needs to be fitted with the supplied heatsink. This should slide over the transistor and form a snug fit.

You should now have mounted all the components on the PCB except the 22pF variable capacitor.

Ensure that you have a 50 Ohm load connected to the RF output and re-apply the power. The following should now happen:

- The '+10V' and '+5V' LEDs should light immediately as before.
- This should be followed, after a few seconds, by the 'LCK' LED and quickly thereafter the 'PWR' LED should glow.

If this happens, then you have successfully completed assembly of the transmitter and can move to setting the frequency. If not, check the voltage at TP2. This should be at least 0.25 Volts.

Setting the frequency

Fit the 22pF variable capacitor next to the octagonal PCB inductor.

The positions of the DIP switches required to set the transmitter to a particular frequency can be found at:

- www.zynq.uk/tx/

When you have set the switches to the correct positions for the frequency you wish to use, re-apply the 12-15V power source. Gently rotate the variable capacitor until the 'LCK' LED lights. Once it has lit, measure the voltage at TP1 and again slowly rotate the variable capacitor until this is in the range of 5V to 8V. This will ensure optimum modulation performance and completely reliable lock.

If using a frequency towards the bottom of the band and if the voltage at TP1 will not rise as high as 5V, add an additional 10pF (or thereabouts) capacitor in the holes next to the 22pF tuning capacitor marked 'NC'.

Carefully compress or expand the turns of inductor L5 (8 turns) to maximise the output power. Some people have found that very slightly expanding or compressing the turns of the three 5 turn inductors can also increase output power.

No other adjustments are necessary. The output power of the transmitter should exceed 500 mW for a 12 Volt supply. With a 15 Volt supply the output power should reach 1 Watt. Do not exceed 15 Volts on the power supply.

Note: Some people have found that replacing the 15 pF capacitor to the right of L7 with an 18 pF capacitor can increase the output power at the very bottom end of the band (i.e. below 90 MHz).

The modulation input to the transmitter is very sensitive, only a few hundred millivolts of audio are required for full deviation. Note that the input is not pre-emphasised and is intended for a pre-emphasised input (or a stereo MPX input). If pre-emphasis is required, please use the following circuit at the audio input to the transmitter (components not supplied).

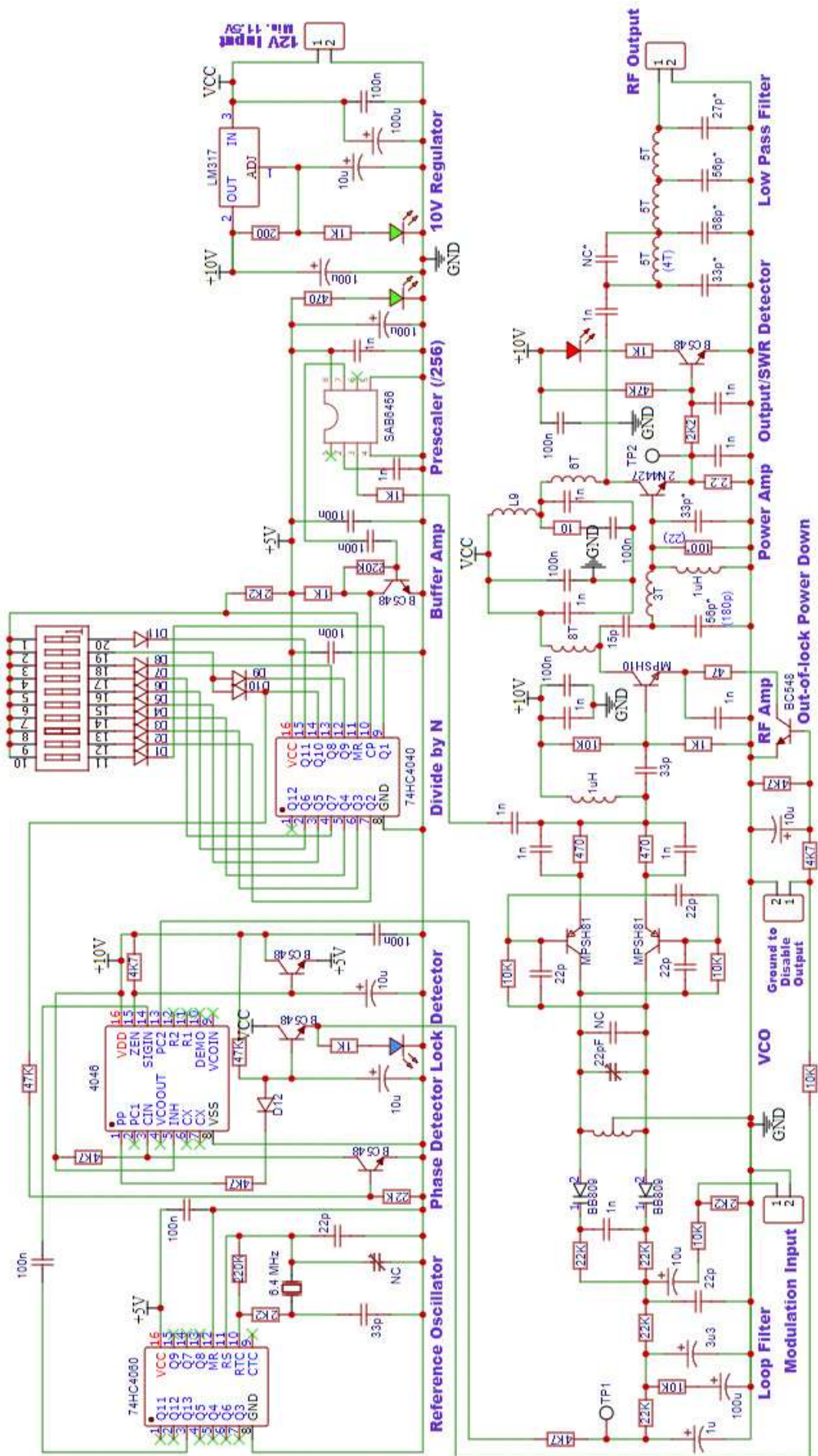

Parts List

Capacitors	Number
15pF Ceramic	1
22pF Ceramic	5
27pF Ceramic	1
33pF Ceramic	3
56pF Ceramic	2
68pF Ceramic	1
1nF Ceramic	13
100nF Capacitor	11
1uF Electrolytic	1
3.3uF Electrolytic	1
10uF Electrolytic	5
100uF Electrolytic	4
Resistors	Number
2.2 Ohm, ¼ Watt	1
10 Ohm, ¼ Watt	1
47 Ohm, ¼ Watt	1
100 Ohm, ¼ Watt	1
200 Ohm, ¼ Watt	1
470 Ohm, ¼ Watt	3
1K Ohm, ¼ Watt	6
2.2K Ohm, ¼ Watt	4
4.7K Ohm, ¼ Watt	6
10K Ohm, ¼ Watt	6
22K Ohm, ¼ Watt	5
47K Ohm, ¼ Watt	3
220K Ohm, ¼ Watt	2
Semiconductors	Number
1N4148 Diode	12
BB809 Diode (or similar)	2
LED (Any Colour)	4
BC548 Transistor	6
MPSH10 Transistor	1
MPSH81 Transistor	2
2N4427	1
LM317 Regulator	1
CD4046 IC	1
74HC4040 IC	1
74HC4060 IC	1
SAB6456 IC	1
Miscellaneous	Number
0.56mm Enamelled Copper Wire	
1uH Axial Inductor	2
Transistor Heatsink	1
10 Way DIP Switch	1
22pF Trimmer Capacitor	1
6.4 MHz Crystal	1

Alternative parts

If building this kit from your junkbox, the following substitutions can be made:

Original	Alternative	Notes
1N4148	1N914 Any small signal silicon diode	
BB809	1SV68 1SV124 BB609	Different varicaps may alter the tuning range slightly. If it is not possible to tune to the bottom of the band, a small value (i.e. 10pF) capacitor may be added in the space next to the 22pF tuning capacitor.
MPSH10	2SC3355 BF199 BF224 / BF241 (need to be installed rotated 180 degrees from that illustrated on PCB) Any TO-92 VHF/UHF RF transistor whose pinout is C-E-B when viewed from left to right when installed on the PCB.	Be sure to check the pinout of any replacement transistor.
BC548B	Any general purpose TO-92 NPN transistor whose pinout is E-B-C as viewed from the left to right when installed on the PCB.	
MPSH81	BF451 Other PNP VHF/UHF transistors can be used but may have different pinouts and need to be installed with their legs contorted.	Be sure to check the pinout of any replacement transistor.
2N4427	2N6255 2SC730 2SC1947 2SC2329 MRF227 MRF237 MRF607 SD1127 TP2314 Carefully check the pinout of the transistor as some require the transistor to be mounted with the 'tab' 180 degrees away from where it is indicated on the board	These alternatives may all produce a slightly higher power output (between 1.5 and 2 Watts). If higher output power is not achieved, the following changes may need to be made to accommodate them: <ul style="list-style-type: none"> • The capacitor marked 56pF* close to the MPSH10 transistor should be replaced by a 150 pF capacitor • The resistor marked 100* should be replaced by a 47 Ohm resistor (this is only necessary if any instability occurs) • L2 should be replaced with a coil with 4 turns (instead of 5)